

5. Maintenance

5.1 Cleaning the Cassette

Keeping the Statim cassette clean is good clinical practice and assists in the function of the unit. SciCan recommends that the interior surface be cleaned at least once a week. Use dishwashing soap or a mild detergent that does not contain chlorine. Scrub the inside of the cassette with a cleaning pad designed for use with Teflon™ coated surfaces. After scouring, rinse thoroughly with water to remove all traces of the detergent. Cleaning the inside of your cassette is very important if you regularly sterilize lubricated instruments. Coating the entire inside surface with STAT-DRI / STAT-DRI PLUS drying agent induces water to form an even coat on the inside surface, without beading. The water in contact with the hot cassette surfaces also evaporates much more efficiently. Spotting is minimized and instruments dry much better. STAT-DRI / STAT-DRI PLUS should be applied every 10 cycles, and after every cassette cleaning.

5.2 Cleaning the Reservoir

Check the reservoir for dirt or particles. The reservoir may be cleaned by draining followed by cleaning and rinsing with steam process distilled water ONLY. Use of chemicals or cleaning agents is not recommended and could cause the unit damage.

5.3 Cleaning the Exterior Surfaces

Use a soft cloth moistened with soap and water to clean all exterior surfaces. Do not use harsh cleaning chemicals or disinfectants.

5.4 Changing the Statim 2000 Air Filter

The filter should be replaced every six months in order to maintain an adequate supply of clean air during the air drying cycle.

To change the filter, follow these steps:

1. Turn the power switch at the back of the unit **OFF**.
2. Remove and discard the old foam air filter **4**.
3. Install the new filter **4** (SciCan part no. 01-100207S).
4. Secure the filter plate **2** to the back of the compressor using the screw **1** retained during the disassembly procedure.

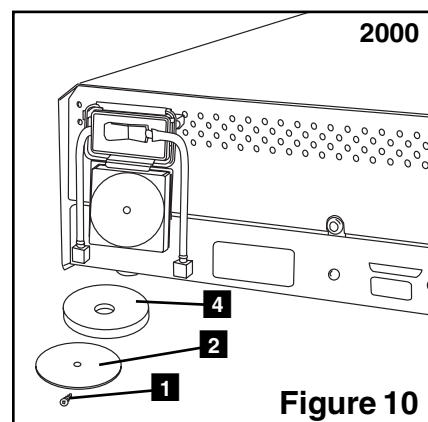

5. Maintenance Cont'd.

5.5 Changing the Bacteria Retentive Air Filters

The filters should be replaced every six months or after 500 cycles to maintain an adequate supply of clean air during the air drying cycle.

To change the bacteria retentive air filter on the Statim 2000 and 5000, follow these steps:

1. Power the Statim **OFF**.
2. Disconnect tube A **1** from the bacteria retentive filter **2** and remove the filter from the filter bracket **3**. As you remove the filter from the bracket, note the orientation of the arrow mark on the filter.
3. When the filter is free of the bracket, carefully disconnect tube B **4** from the filter.
4. Before installing the replacement bacteria retentive filter **2** (SciCan order no. 01-102119S) check that the arrow mark on the filter matches the direction of the arrow on the bracket. Push the left hand filter fitting into tube B **4**.
5. Gently press the replacement filter into the filter bracket **3**. The arrow mark of the filter should be facing out and pointing to the left.
6. Re-connect tube A **1** to the right hand filter fitting.

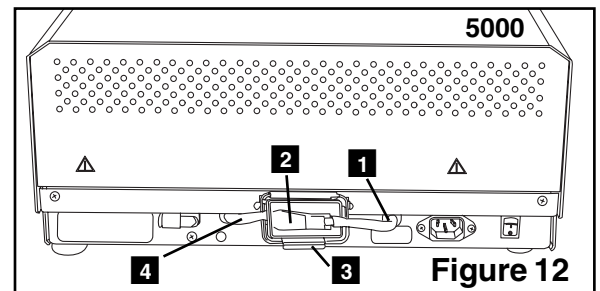
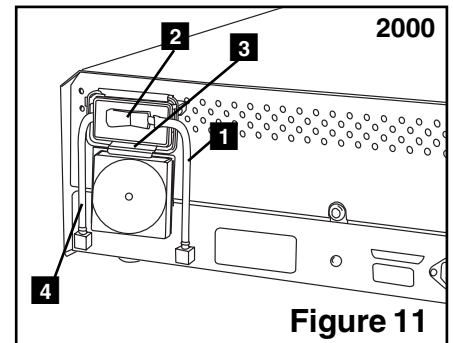

5.6 Replacing the Cassette Seal

To ensure optimum performance of your Statim cassette autoclave, change the cassette seal every 500 cycles or every six months, whichever comes first. Replacement seals are available from SciCan (order number 01-100028S for Statim 2000 and 01-101649S for Statim 5000).

When replacing the cassette seal, the cassette channel must be flushed with distilled water. The old seal is removed, the cassette channel is flushed with distilled water and then followed by replacement with the new seal.

5. Maintenance Cont'd.

To change the cassette seal, follow these steps:

Place the cassette lid and the new seal on a clean work surface. Examine the position of the old seal in the cassette lid and arrange the new seal in the same orientation, next to the lid.

Remove the old seal and discard. Clean any residue out of the seal channel and flush out the channel with distilled water.

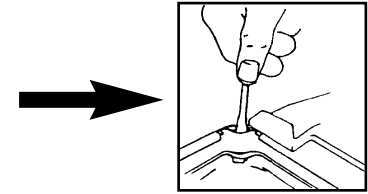

Lubricate the new seal with the liquid seal lubricant provided.

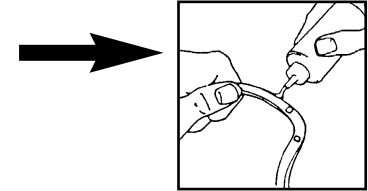

Insert the rounded edge of the seal under the round lip of the lid. Align the holes in the new seal with the holes in the lid.

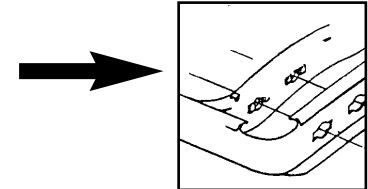

NOTE: At every corner, two square nibs should be visible.

Ensure the seal is completely inserted. Feel around the periphery to ensure the seal is securely in place.

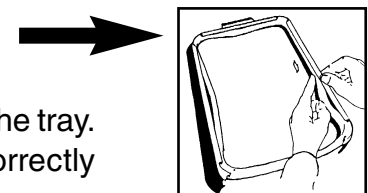

NOTE: During a cycle, steam may appear between the lid and the tray. If this persists, remove the cassette and check that the seal is correctly installed.

Figure 13



Be careful. The metal parts will be hot, and the cassette may contain hot steam.

5.7 Maintaining Fluid Levels

Use only steam-process distilled water containing less than 5 ppm total dissolved solids (having conductivity of less than 10 $\mu\text{S}/\text{cm}$) in the Statim. To fill the reservoir, remove the cap from the top of the unit and fill the reservoir. We recommend using a funnel to minimize spills. Each time you refill the reservoir, empty the waste bottle and refill with water to the MIN line. Empty the waste often to avoid unpleasant odors and discoloration of the contents. (A low-level chlorine-free disinfectant, prepared according to the manufacturer's instructions, may be added to the waste bottle to remedy this situation).

5.8 Preventative Maintenance Schedule



To ensure trouble-free performance, both the operator and the dealer must follow a preventative maintenance schedule.

NOTE: Please refer to your National, Regional, State or Safety laws for any additional reoccurring user testing that may be required.

5. Maintenance Cont'd.

The schedules below describes the necessary actions.

| Operator | | |
|------------------|-----------------------|--|
| Daily | Cassette | Wash the interior of the cassette with chlorine-free dishwashing detergent or soap. Rinse thoroughly with water. |
| | Unit | To ensure optimal performance of the Statim autoclave, SciCan recommends that a full sterilization cycle, which must include the full Air Drying phase, be completed at the end of each day of use. This is especially important when the unit is left idle over the weekend or for any extended period of time. |
| | Water Reservoir | Drain Daily |
| | Waste Bottle | Empty the waste bottle every time you refill the reservoir. Fill with tap water up to MIN line. You can also add some chlorine-free disinfectant. |
| Weekly | Air Filter | Check the air filter for dirt and moisture. Replace if dirty. Call for service if wet. |
| | Biological Air Filter | Check the air filter for dirt and moisture. Replace if dirty. Call for service if wet. |
| Every six months | Air Filter | Replace every 500 cycles or six months (whichever comes first). |
| | Biological Air Filter | Replace every 500 cycles or six months (whichever comes first). |
| | Cassette Seal | Replace every 500 cycles or six months (whichever comes first). |

| Technician | | |
|-------------------|-----------------|--|
| Once a year | Cassette | Check the tray, lid and seal for damage. Replace if necessary. |
| | Air Filters | Check the filters. Replace if dirty. |
| | Solenoid Valve | Inspect the valve and clean if dirty. Replace the plunger if defective. |
| | Pump | Clean the filters, replace if dirty. |
| | Check Valve | Remove the air compressor tube from the check valve inlet while running a cycle. Make sure no steam is leaking from the valve. Replace if there are any leaks. |
| | Water Reservoir | Check the reservoir for dirt. Clean and rinse with steam process distilled water if necessary. |
| | Calibration | Calibrate the unit. |