



VATECH ASSURANCE

VATECH IMAGING SYSTEMS

vatech america

VATECH IMAGING SYSTEMS

About Vatech America	3
Vatech Assurance	4
PaX-i	5
PaX-i Insight	10
i3D Smart	14
Green CT	18
Green CT 2	23
i3D Premium	27
Ez3D-i	31
EzDent-i	34
EzRay Air Wall	35
HD Sensor	38



VATECH ASSURANCE

vatech america

World's Premier Dental Imaging Company

Vatech is a leading manufacturer of radiographic imaging solutions for the medical, dental, and veterinary fields with offices in over 70 countries worldwide.



MISSION: *With honesty and integrity, we strive to be the industry leader and preferred partner by providing innovative imaging solutions and first class client services that ultimately enhance the quality of patient care.*



As the US subsidiary of Vatech, Inc. Vatech America is committed to providing the industry with innovative dental x-ray imaging solutions while maintaining a primary focus on ultimately enhancing the quality of patient care.

From the world's first 3-in-1 digital x-ray system to low radiation CBCT devices, Vatech America is the clinicians' preferred vendor for their diagnostic imaging endeavors.

A History of World Firsts

2005	2007	2008	2009	2013	2017
Launched World's First 3-in-1 Digital X-ray System: Picasso-Trio	Launched World's First Auto-Switching System: PaX-Duo3D	World's First One Shot Cephalometric: PaX-Uni3D	World's First Free FOV System: PaX-Reve3D	Groundbreaking Low Radiation System: Green CT	41-Layer Digital Panoramic Radiograph: PaX-i Insight



VATECH ASSURANCE

What is Vatech Assurance?

Vatech Assurance, a core value of Value Added Technologies, is our promise to our customers that we will not only provide a premium dental imaging system to suit your needs, but also to ensure the value of your investment from becoming obsolete by providing multiple options for upgrading to the newest technologies as they are developed. Whether it's a defined transition strategy to newer technologies, or protection of currently owned technology, Vatech Assurance provides industry leading service, support, warranty coverage, as well as added value that reaches beyond the x-ray itself.

No Asterisks | No Legalese | Just Vatech Assurance



BUYBACK PROGRAM

What is the Vatech Buyback Program?

Within three years of the installation date, Vatech and your supporting dealer will buyback your 2D imaging system, applying 100% of the original purchase price you paid towards an eligible brand new 3D imaging system. Rather than upgrading the hardware of an aging imaging system, Vatech will provide a BRAND NEW 3D imaging system if you choose to exercise this policy. 0% Depreciation!

Maintain your upgradability by resetting your technology with a BRAND NEW device with the Vatech Buyback Program.



TRADE IN/UP PROGRAM

What is the Vatech Trade in/Trade up Program?

As technology rapidly evolves, protecting your investment from accelerated depreciation can be found exclusively in the Vatech Trade in/Trade up Program.

Vatech will provide a trade in value for your 3D imaging system, utilizing a *lower-than-market depreciation rate*, allowing you to maximize the return for your imaging system when it's time to upgrade to a new 3D device.

Minimize your long term costs, maximize the residual value of your imaging system, and upgrade to newer and more advanced technology with ease by participating in the Vatech Trade in/Trade up Program.

Partnership | Commitment | Peace of Mind | Vatech Assurance

YOUR PARTNER IN DIGITAL SUCCESS,

PaX-iTM



SUPERIOR IMAGE QUALITY

- Optimal image for accurate diagnosis

TWO DEDICATED SENSORS

- Specialized sensors for Pano & Ceph
- Streamlined workflow and prolonged lifespan of sensors

USER-FRIENDLY SOFTWARE, EZDENT-I

- Complete diagnostic and consultation solution

THE ADVANCED IMAGING SOLUTION FOR ACCURATE DENTAL DIAGNOSIS

The PaX-i provides the most precise and high quality panoramic images by combining image processing and accumulated experience in dental imaging from Vatech. This will increase your diagnostic accuracy for improved treatment planning and patient satisfaction.



MAKE YOUR DIAGNOSIS EASY AND EFFICIENT WITH VARIOUS CAPTURE MODES



Bitewing Mode



TMJ Mode

SELECTION	ARCH	EXAMINATION MODE
PANO EXAMINATION	Narrow / Normal Wide / Child	Standard / Right / Front / Left
	Orthogonal	Orthogonal Standard / Right / Front / Left Bitewing Standard / Right / Front / Left
SPECIAL EXAMINATION	Normal	TMJ LAT Open / Close TMJ PA Open / Close Sinus LAT / PA



TWO DEDICATED SENSORS

The PaX-i offers two dedicated and embedded sensors for Pano and Ceph. This not only allows you to capture an optimal image from each sensor, but it also creates an efficient workflow.



CEPHALOMETRIC (SCAN CEPH)

The PaX-i provides optimal images exclusively designed for orthodontics. There are two image sizes available, Lateral and Full Lateral, allowing you to choose your image size based on your diagnostic needs.



LATERAL

Provides specialized high quality images to suit orthodontics and maxillofacial surgeries.



FULL LATERAL

A full lateral image size is 30% wider and shows the occipital area of the patient, which enables comprehensive diagnosis.

EXAMINATION PROGRAM	SCAN TIME	IMAGE SIZE
LATERAL	12.9 sec	21x23 cm (8.3"x9.1")
FULL LATERAL	16.9 sec	27x23 cm (10.6"x9.1")



ONE SHOT CEPH

With One Shot Ceph, you can acquire high quality images with low x-ray dosage. Plus, short scan time markedly reduces motion artifacts.

CEPHALOMETRIC (ONE SHOT TYPE)

Superior image quality will be delivered using the a-Si TFT sensors. Three different ceph image sizes reduce unnecessary x-ray dosage and scan the ideal area of cranial anatomy for your diagnosis and treatment planning.

LATERAL

30x25 cm (12"x10")



OP (One Shot Premium)

PA



Carpus



SMV(Submentoververtex)



PRODUCT CONFIGURATION

	PANO	CEPH	
		SCAN	ONE SHOT
PaX-i	•	—	—
PaX-i SC	•	•	—
PaX-i OP	•	—	•

SPECIFICATIONS (PaX-i: PCH-2500)

Function	Pano + Ceph	Ceph FOV Size	SC 8.3"x9.1" [LAT, PA, SMV, Waters View, Carpus] 10.6"x9.1" [Full LAT]
Scan Time	Pano : HD 13.5 sec / Normal 10.1 sec Ceph : Scan 12.9 sec / One Shot 0.9 sec	Ceph FOV Size	OP 12"x10" [LAT, PA, SMV, Waters View, Carpus]
Focal Spot	0.5 mm	Gray Scale	14 bit
Tube Voltage/ Current	50-90 kVp / 4-10 mA	Patient Positioning	Standing / Wheelchair Accessible

DIMENSIONS

PaX-i Pano

TOP VIEW

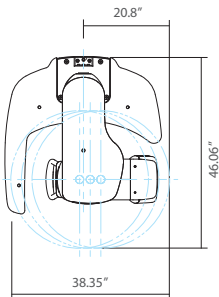

FRONT VIEW

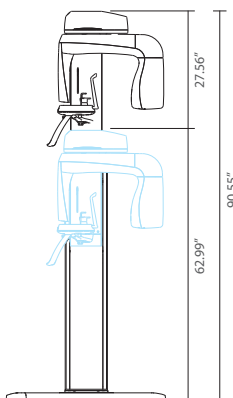

PaX-i SC Pano / Scan Ceph

TOP VIEW

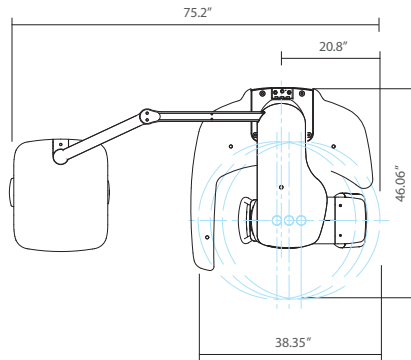

FRONT VIEW

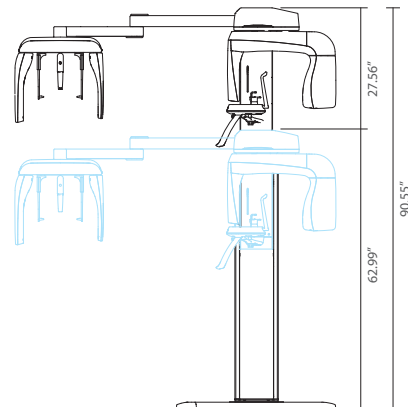

PaX-i OP Pano / One Shot Ceph

TOP VIEW

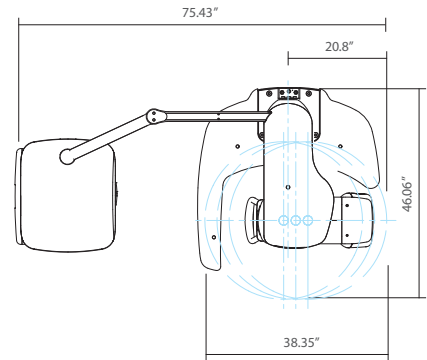

FRONT VIEW

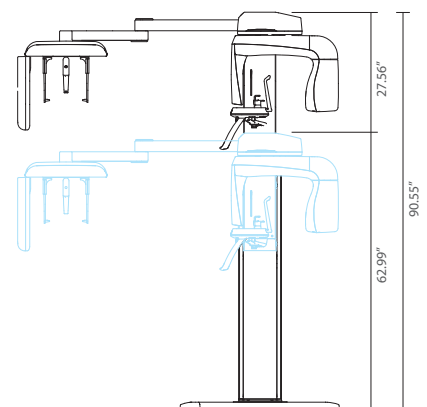

BEYOND 2D, DEPTH ADDED PANORAMA

PaX-i Insight™

41
MULTI
LAYERS

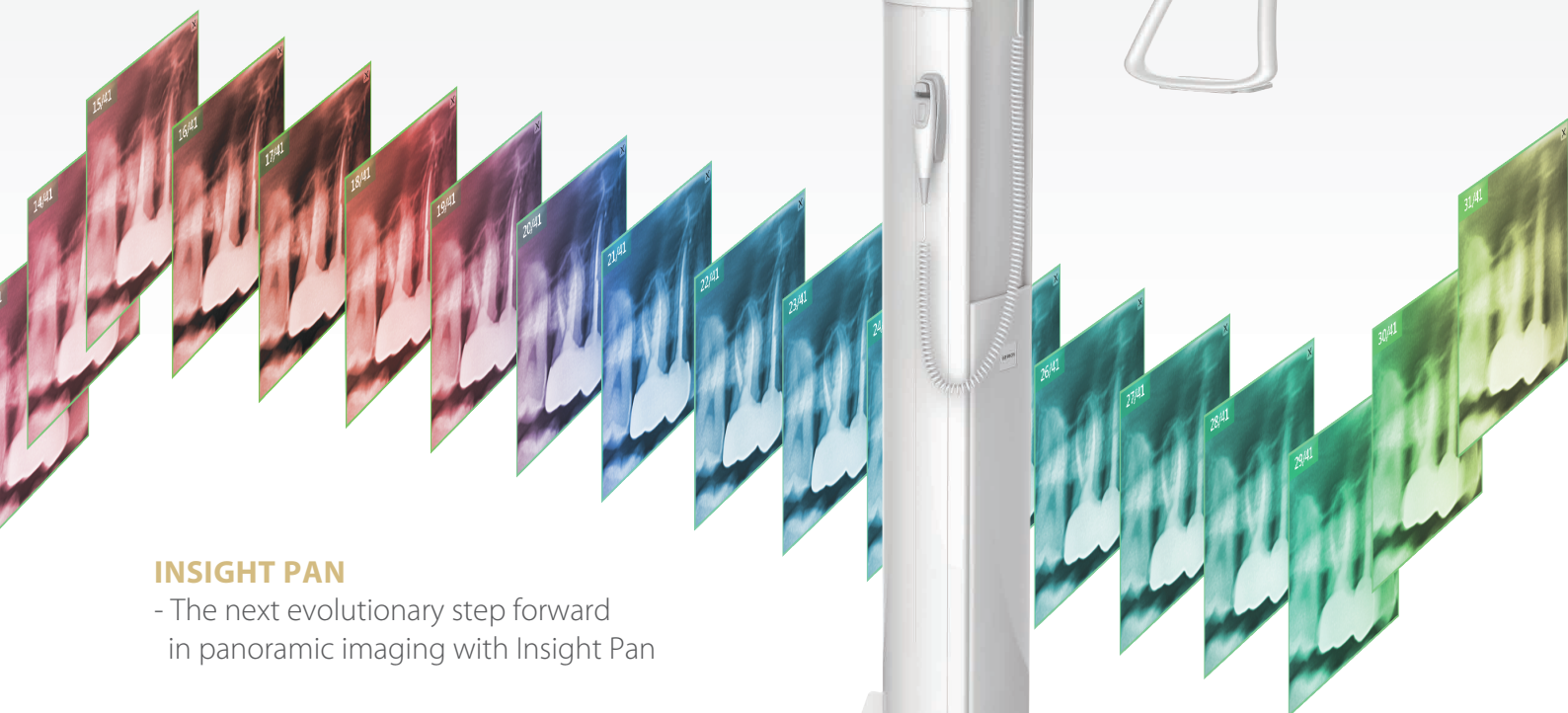

INSIGHT PAN

- The next evolutionary step forward in panoramic imaging with Insight Pan

RAPID CEPH

- 1.9 second acquisition time produces superb image quality
- Reduced motion artifacts and faster workflow

USER-FRIENDLY EZDENT-I SOFTWARE

- Powerful diagnostic value with Insight feature
- Complete solution for consultation
- Easy to learn, easy to use

ADVANCED IMAGE SOLUTION WITH INSIGHT PAN

The next evolutionary step forward in panoramic imaging.

The PaX-i Insight is capable of taking a multi-layered panoramic image called an Insight Pan which provides a unique, in-depth look across a single focal trough.

Since each patient may have a slightly different arch, conventional panoramic images may occasionally miss important details which land outside of a single focal layer.

Insight Pans are capable of capturing multiple-layered images, ensuring that all details are captured in a depth-added panoramic image.

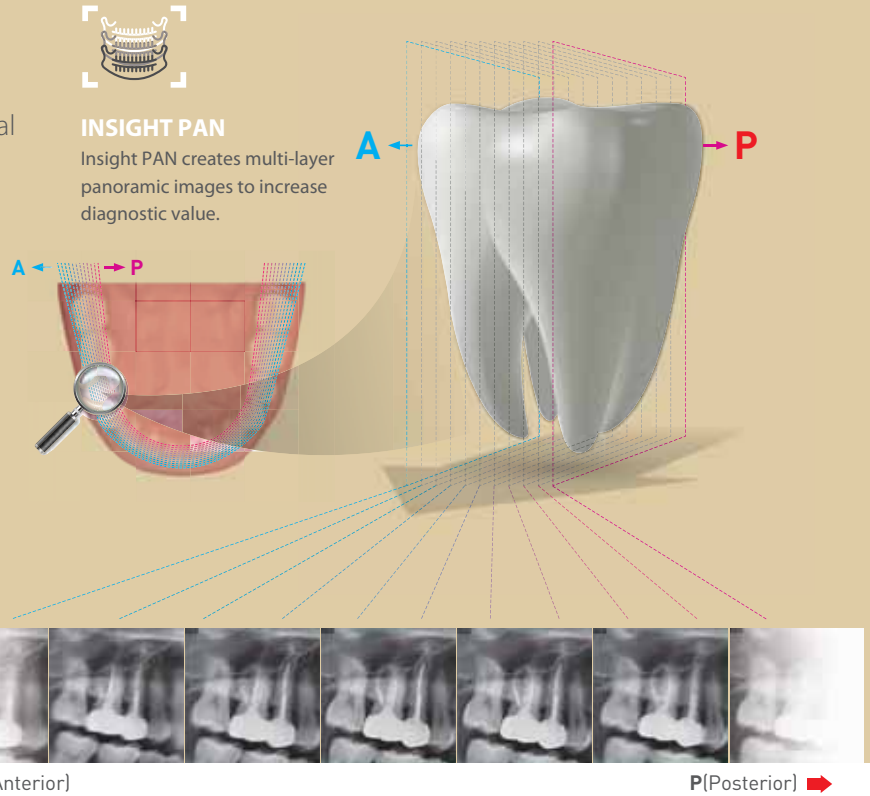

MINIMIZE MOTION ARTIFACTS WITH RAPID CEPH TECHNOLOGY

The next step in cephalometric technology, Vatech's new Rapid Ceph minimizes motion artifacts and enables faster diagnostic workflow while providing the highest quality digital images.

GREAT CLINICAL CARE WITH RAPID CEPH TECHNOLOGY



EZDENT-I: QUICK AND EASY DENTAL IMAGING SOFTWARE

EzDent-i provides a wide array of functions designed to streamline the dental practice's workflow. It conveniently provides tools for specialized diagnosis and consultation via our easy-to-use user interface.



Diagnosis

- Depth added diagnostics with Insight Pan



Simulation

- 2-click implant simulation
- Natural tooth whitening simulation
- Simplified canal tracing



Consultation

- 244 consultation videos
- Add user-created consultation content

WHAT IS INSIGHT?

The next-generation in panoramic technology, Insight Pans allow doctors to obtain never before seen, in-depth diagnostic information from the anterior to posterior on a digital panoramic image.

The Insight feature allows doctors to explore their region of interest, giving them the capability to find mesiobuccal, distobuccal, and even palatal root information.

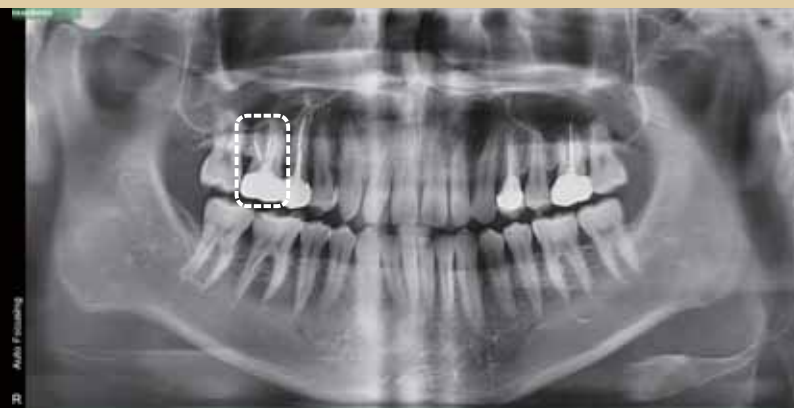

STANDARD PANORAMA

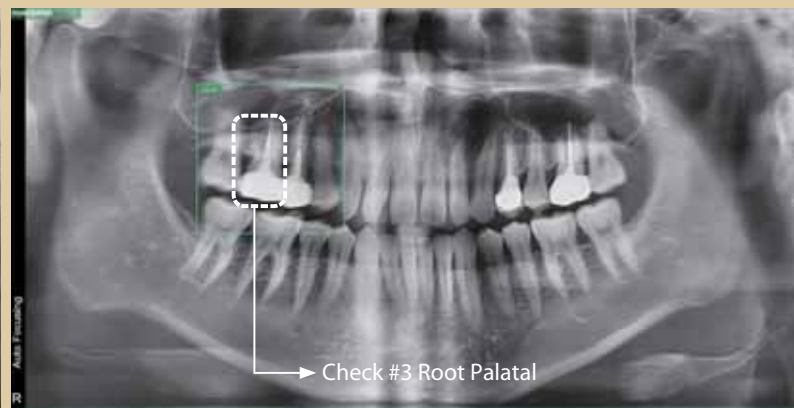

INSIGHT FEATURE

Use the PaX-i Insight's Next Generation Panoramic Technology to Discover:

- Hidden multi roots and canals
- Location of pulp and gutta-percha
- Broken files or root fractures

PRODUCT CONFIGURATION

	PANO	CEPH
PaX-i Insight	•	–
PaX-i Insight SC	•	•

SPECIFICATIONS (PaX-i Insight : PCH-30CS)

Function		Pano + Ceph	
Focal Spot		0.5 mm (IEC60336)	
Scan Time	Pano	Normal	10.4 / 14.0 / 21.0 sec
		Insight PAN	10.4 sec
	Ceph	1.9 / 3.9 sec	
Gray Scale		14 bit	
Tube Voltage / Current		60 ~ 99 kV / 4 ~ 10 mA	
Weight	Without Ceph unit	209.4 lbs. – without Base	
		297.6 lbs. – with Base	
	With Ceph unit	264.5 lbs. – without Base	
		352.7 lbs. – with Base	
Dimensions	Without Ceph unit	38.98 Inch (L) x 47.24 Inch (W) x 90.55 Inch (H)	
	With Ceph unit	75.98 Inch (L) x 47.24 Inch (W) x 90.55 Inch (H)	

* The specifications are subject to change without prior notice.

DIMENSIONS

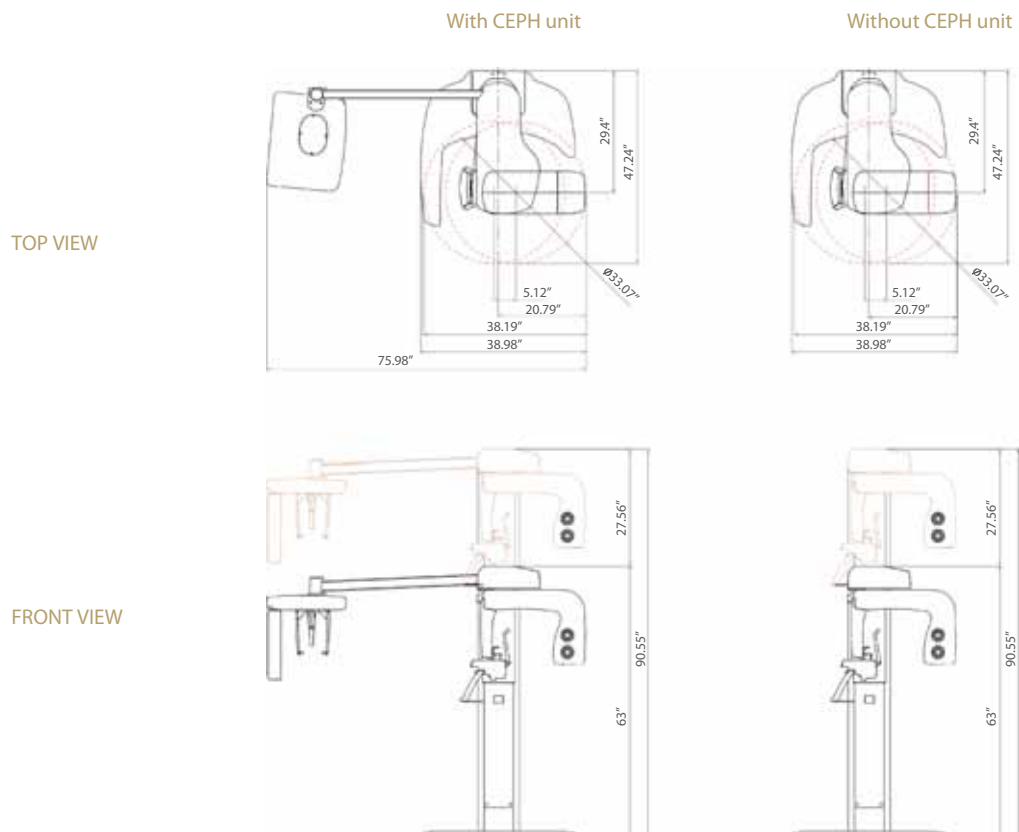

No More than what you *want*,
No Less than what you *need*.

i3D *Smart*



-  **ONE SCAN, TWO IMAGES**
-  **EXTENDED ARCH SHAPED FOV**
-  **INNOVATIVE COMPRESSED SENSING TECHNOLOGY**
-  **3D SCANNING FOR MODEL**

SMART INNOVATION

ONE SCAN, TWO IMAGES

One scan with the i3D Smart gives you not just a CT image, but also an Auto Pano image. This means, patients who require both images do not need to undergo two x-ray scans. Also, CT and Auto Pano images are displayed within one viewer.



* Conventional panorama mode is provided.



[2D AND 3D IN ONE VIEWER]

Viewing 2D and 3D images together provides many benefits. There is no need to utilize two different software programs and the one viewer feature presents a professional look for your patients.

This layout helps patients better understand the images, which will eventually result in increasing acceptance rates.

EXTENDED ARCH SHAPED FOV

The innovative FOV of the i3D Smart provides an arch-shaped volume, which shows a wider view of the dentition compared to other devices of the same FOV. When a tooth is lying on its side, there is a high possibility that the tooth will be cut out of the image. The “arch-shaped volume” eliminates this possibility and shows the hidden dentition area.

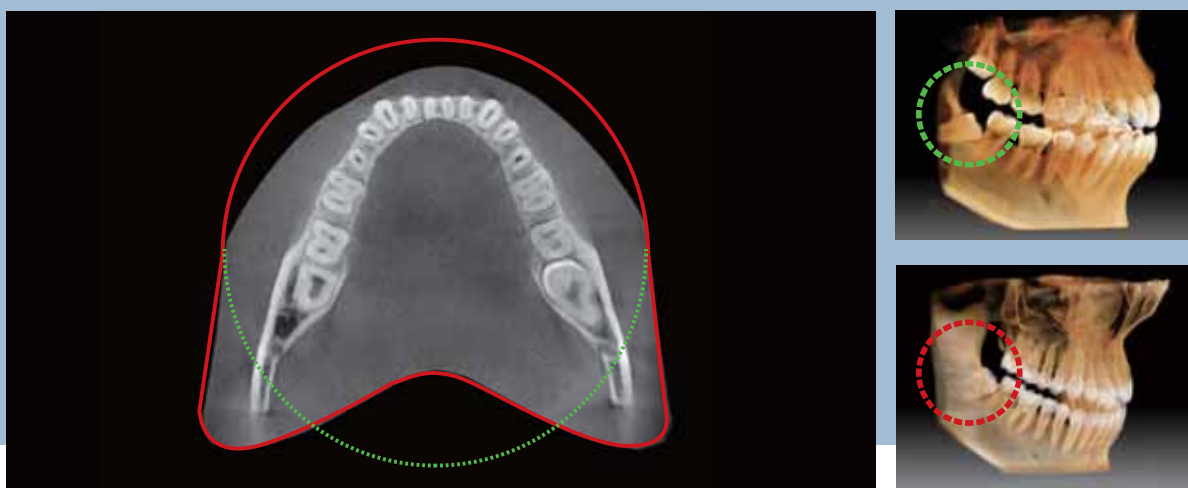

INNOVATIVE COMPRESSED SENSING TECHNOLOGY

3D image quality has dramatically improved based on the innovative image reconstruction technology.

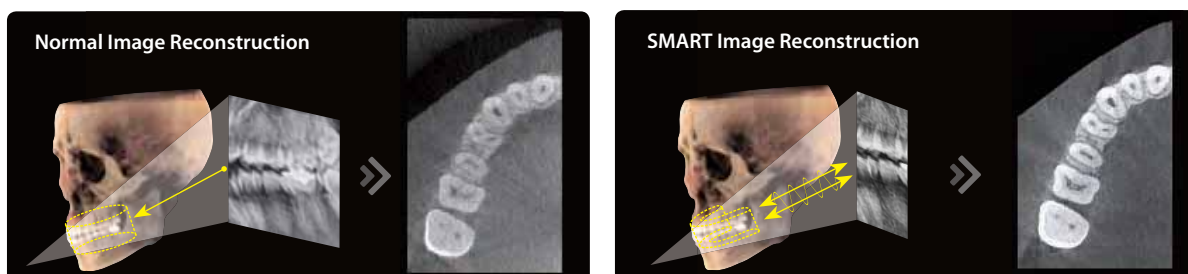

3D SCANNING FOR MODEL

3D model scanning enables users to store plasters as digital models.

DIGITIZED ONE-STOP CLINIC



CAD/CAM integration
 • Sufficient level of detail for surgical guide design



Specially designed Jig
 • Stable platform from partial model to full model scanning

* 3D scanning for Plaster Cast with FOV 10x8.5 (cm)

PRODUCT CONFIGURATION

	CBCT	PANO	CEPH
i3D Smart	•	•	
i3D Smart RC	•	•	•

SPECIFICATIONS (i3D Smart : PHT-35LHS)

Function	CT (with Auto Pano) + Pano + Ceph + Model Scan	
Focal Spot	0.5 mm (IEC 60336)	
CT FOV Size	5x5 cm / 10x8.5 cm (Anatomical 12x9 cm)	
Voxel Size	0.08 mm / 0.12 mm / 0.2 mm / 0.3 mm	
Scan Time	CT	18 sec
	Pano	14.1 sec / 7 sec
	Ceph	1.9 sec / 3.9 sec
Gray Scale	14 bit	
Tube Voltage	60 ~ 99 kV	
Current	4 ~ 16 mA	
Weight	With Ceph unit	357.1 lbs

*The specifications are subject to change without prior notice.

DIMENSIONS (Unit: inch)

Without CEPH unit

TOP VIEW

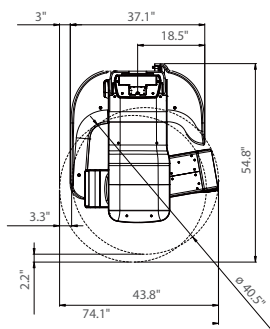

FRONT VIEW

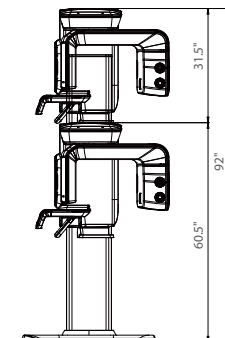

With CEPH unit

TOP VIEW

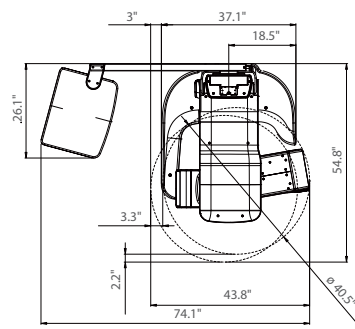

FRONT VIEW

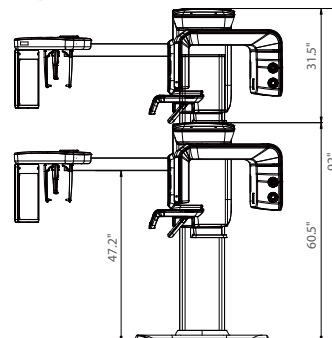

SIDE VIEW

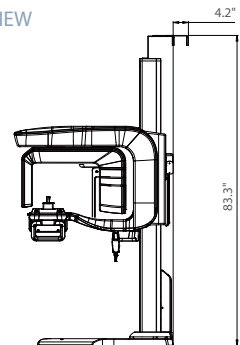

FRONT VIEW

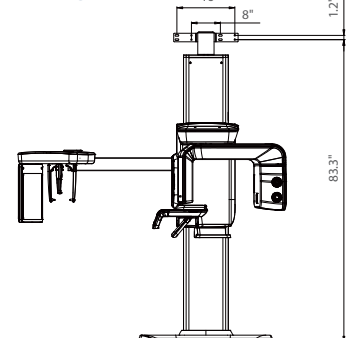

***An additional 3 inches (76.2 mm) of space is required behind the unit for wall mount bracket installation (mandatory unless there is a base mount installation).**

THE NEW DIGITAL ENVIRONMENT



GREEN CBCT

- VATECH's innovative technology for an ultra low x-ray dose
- Green CBCT protects both patient and user

RAPID SCAN

- Minimized motion artifact and faster workflow
- Superb image quality from a rapid **9 sec** scan

MULTI FOV SIZES

- Wide range of FOV sizes from 5x5 to 17x15
- Optimal size for specific diagnosis, reducing x-ray exposure to patients

EASY AND SIMPLE SOFTWARE, EZ3D-I

- Easy to learn, easy to use
- Intuitive user interface and powerful consulting tools



PATENTED AUTO-SWITCHING TECHNOLOGY

The Green CT offers convenient and safe 'Patented Auto-Switching Technology' system, that switches between CBCT and Panoramic sensors. This smart system conveniently prevents sensor damage from accidental dropping.

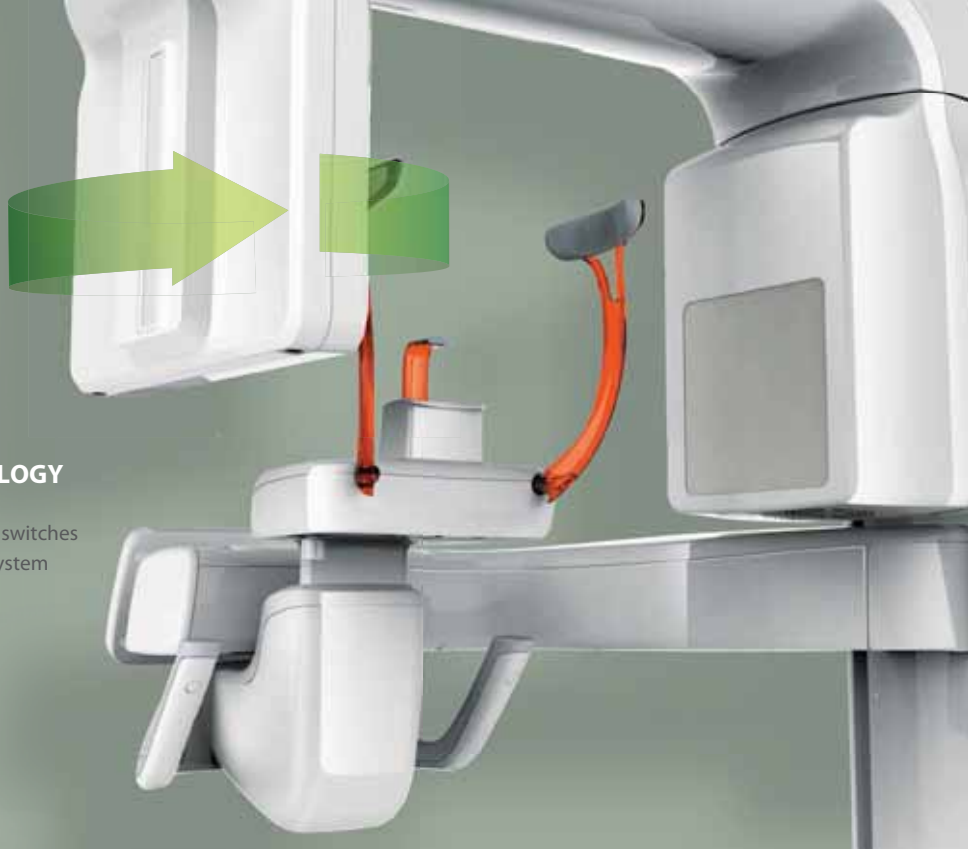

PROFESSIONAL DIAGNOSTIC VALUE WITH 3D IMAGES

WIDE RANGE OF DIAGNOSIS WITH MULTI FOV SELECTION

With expanded FOV sizes, the Green CT offers valuable diagnostic tools for clinicians.

Clinical Care with GREEN INNOVATION

The Green CT produces superb diagnostic images, which will be a source of pride for any dental practice, and improves treatment planning and safety for your patients.

Experience excellent image quality with Vatech's advanced technology.



Highest quality of patient care



Superior image quality



Increase workflow efficiency

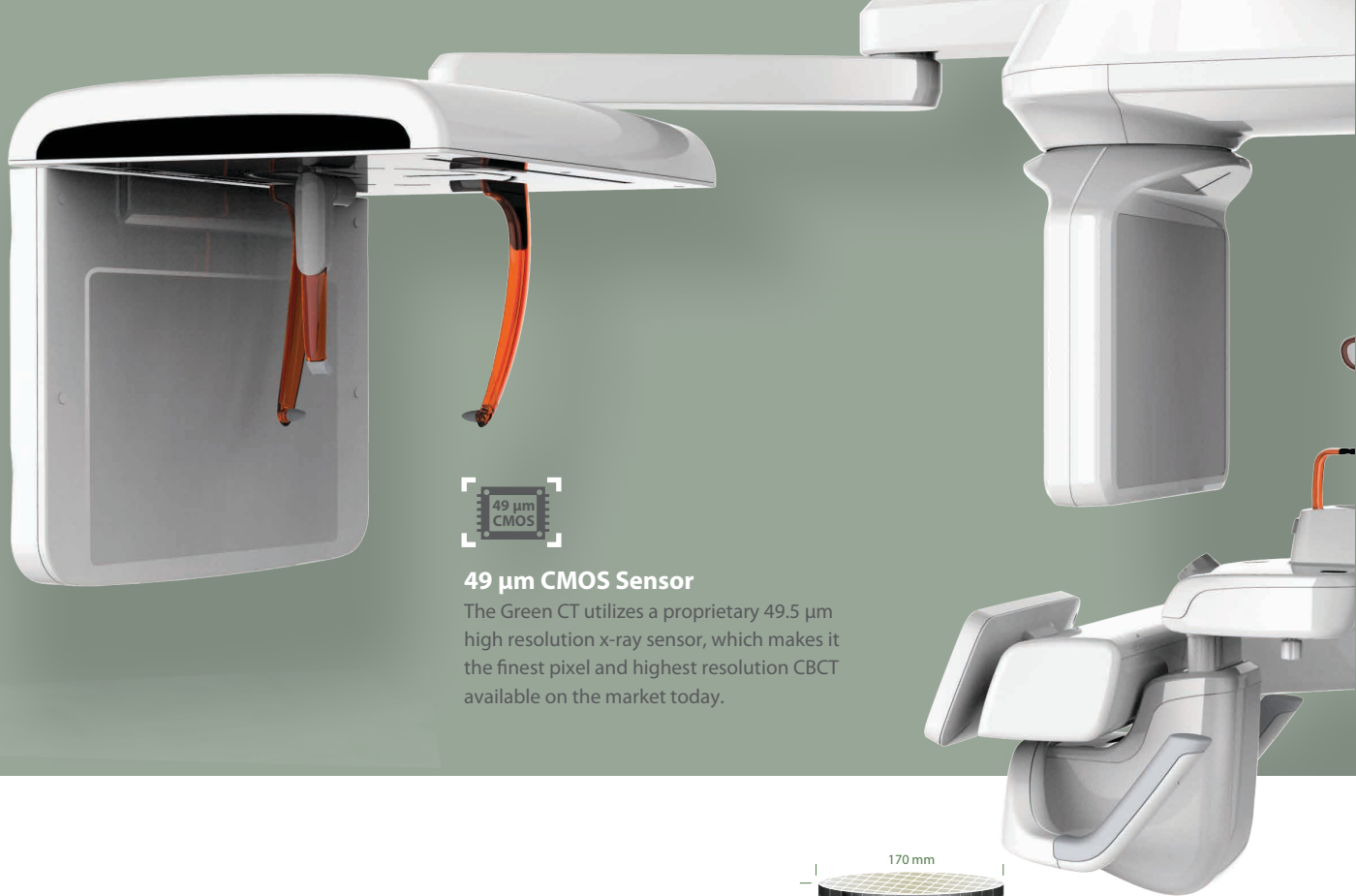

49 µm CMOS Sensor

The Green CT utilizes a proprietary 49.5 µm high resolution x-ray sensor, which makes it the finest pixel and highest resolution CBCT available on the market today.

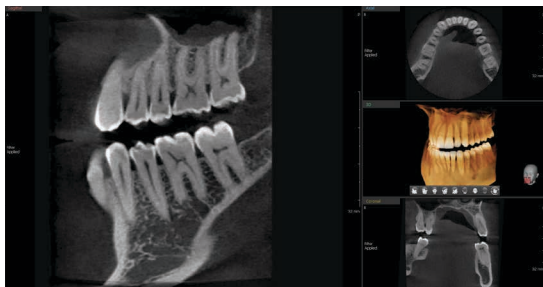
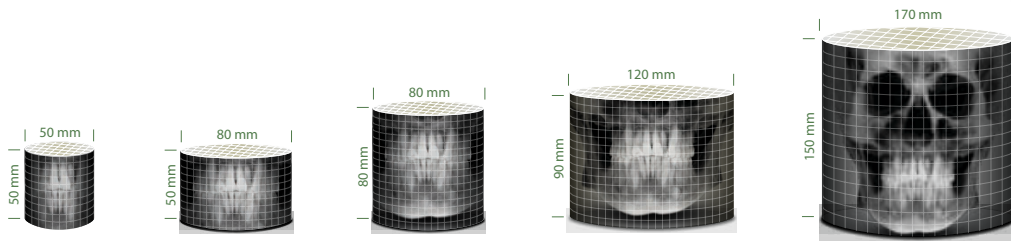

FOV 8x8

8x8 images enable comprehensive diagnosis and treatment planning including both maxillary and mandibular areas in a single scan. It is useful for complex implant surgery as well as left or right TMJ diagnosis.

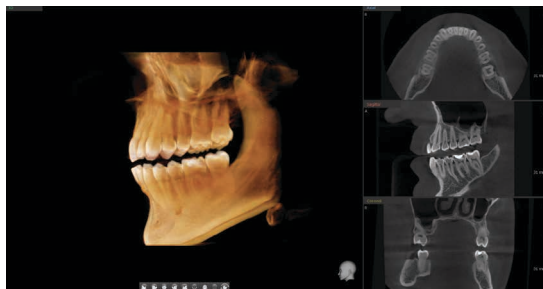

FOV 12x9

12x9 images can provide the most optimal information for oral diagnosis fully covering both maxillary and mandibular structures including the 3rd molar region in a single scan. It is suitable for most oral surgery cases as well as multiple implant surgery.

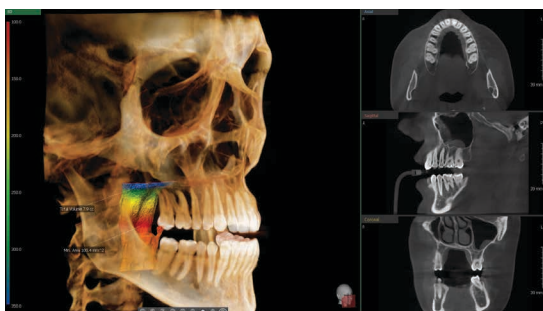

FOV 17x15

17x15 images from the Green CT enable you to do a comprehensive diagnosis including oral and maxillofacial surgery. This perfect FOV size will be helpful for complex orthognathic, implant, and orthodontic surgery.

PROFESSIONAL DIAGNOSTIC VALUE WITH CEPHALOMETRIC IMAGES

EXTENDED DIAGNOSTIC VALUE FOR WIDE INSIGHT

CEPHALOMETRIC (SCAN TYPE)

The Green CT provides optimal images with an exclusively designed sensor for cephalometric diagnosis. As it offers two image sizes, LAT and Full LAT, you can choose one of them based on the purposes of your diagnostic needs.

Built-in Sensor System

The Green CT enables you to acquire high quality images in a safe and comfortable environment. Best of all, you don't need to waste time or risk damage by changing sensors.



LATERAL

Provides specialized high quality images to suit orthodontics and maxillofacial surgeries.



FULL LATERAL

A full lateral image size is 30% wider and shows the occipital area of the patient, which enables comprehensive diagnosis.

EXAMINATION PROGRAM	SCAN TIME	IMAGE SIZE
LATERAL	3.9 sec	21x23 cm (8.3"x9.1")
FULL LATERAL	16.9 sec	27x23 cm (10.6"x9.1")

PRODUCT CONFIGURATION

	CBCT	PANO	CEPH
Green CT	•	•	-
Green CT SC	•	•	•

SPECIFICATIONS (Green CT : **PHT-60CFO**)

Function	Pano + CBCT + Ceph
CT - FOV Size	17x15 cm : Multi [5x5 / 8x5 / 8x8 / 12x9 / 17x15 cm]
Voxel Size	5x5 cm : 0.08 mm / 0.2 mm 8x8, 12x9 cm : 0.2 mm / 0.3 mm 17x15 cm : 0.25 mm / 0.3 mm
Scan Time	Pano : 10.1 sec Scan Ceph : 3.9 sec CBCT : 9 sec / 15 sec

Ceph FOV Size	SC 8.3"x9.1" [LAT, PA, SMV, Waters View, Carpus] 10.6"x9.1" [Full LAT]
Gray Scale	14 bit
Patient Position	Standing / Wheelchair Accessible
Tube Voltage/ Current	50-100 kVp(1 kV step) / 4-16 mA(0.1 mA step)

DIMENSIONS

Green CT

Pano / CBCT

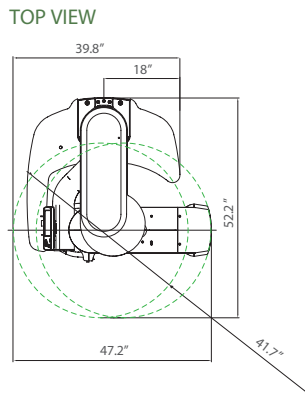

FRONT VIEW

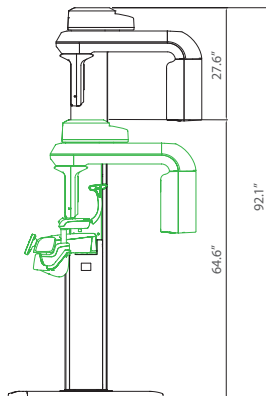

Green CT SC

Pano / CBCT / Scan Ceph

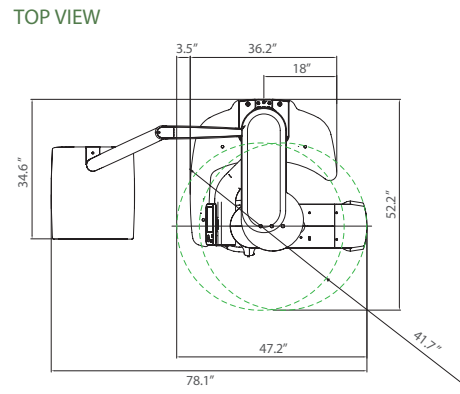

FRONT VIEW

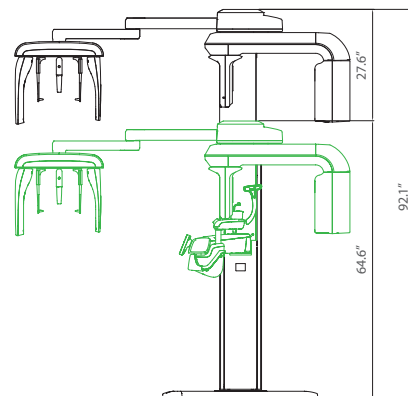

*** An additional 7.5 inches (191 mm) of space is required behind the unit for wall mount bracket installation (mandatory unless there is a base mount installation).**

THE NEXT GREEN INNOVATION



- **4-IN-1 DIGITAL** [PANO | CEPH | CBCT | MODEL]
- **MULTI FOV SELECTION**
- **GREEN SCAN TIME**
- **LOW DOSE AND HIGH IMAGE QUALITY**
- **THE ART-V**
- **3D SCANNING FOR MODEL**



THE ADVANCED 4-IN-1 DIGITAL X-RAY IMAGING SYSTEM

The Green CT 2 is an advanced 4-in-1 digital x-ray imaging system that incorporates PANO, CEPH (Optional), CBCT, and MODEL Scan.



It provides high quality images with lower radiation by combining image processing and accumulated experience in dental imaging from Vatech. This will improve your diagnostic accuracy with increased treatment planning and patient satisfaction.

The Green CT 2 utilizes a proprietary 49.5 μm high resolution x-ray sensor, which makes it the finest pixel and highest resolution CBCT available on the market today.

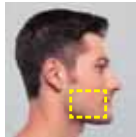
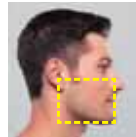

MULTI FOV SELECTION

The Green CT 2 offers a range of selectable fields of view. The Multi FOV enables the user to select the optimal FOV mode and minimizes exposure to areas not in the region of interest. Select the proper FOV size among 18x10, 16x9, 13x10, 12x9, 8x9, and 5x5 based on a particular diagnostic need. It covers the full arch region, sinus, and left/right TMJ and it suits most oral surgery cases as well as multiple implant surgeries.

Endo & Single implant	Arch	Dual Arch	Sinus & TMJ
5x5	8x9	12x9 / 13x10	16x9 / 18x10
			
Optimal size to cover 3~4 teeth through capturing ROI	Basic FOV size & select a left or right or center arch	Suitable for multiple implant surgeries	Optimal size for sinus & TMJ diagnosis

GREEN SCAN TIME

The Green CT 2 minimizes motion artifact and enables faster workflow due to its scan time.

It produces superb diagnostic images, which will be a source of pride for any dental practice. Focusing on the highest quality of patient care, Vatech strives to improve the health and safety of your patients.



Ceph



CBCT



Pano



LOW DOSE AND HIGH IMAGE QUALITY

What has been developed at Vatech breaks many conventions in dental radiography. It was always believed that with low radiation comes inferior image quality, which renders it useless in clinical diagnosis. However, the Green CT 2 provides clinically diagnosable x-ray scans at a low x-ray dosage. With low dose radiography, achieving clinically diagnosable image quality is the new golden-standard.

Effective Dose Data

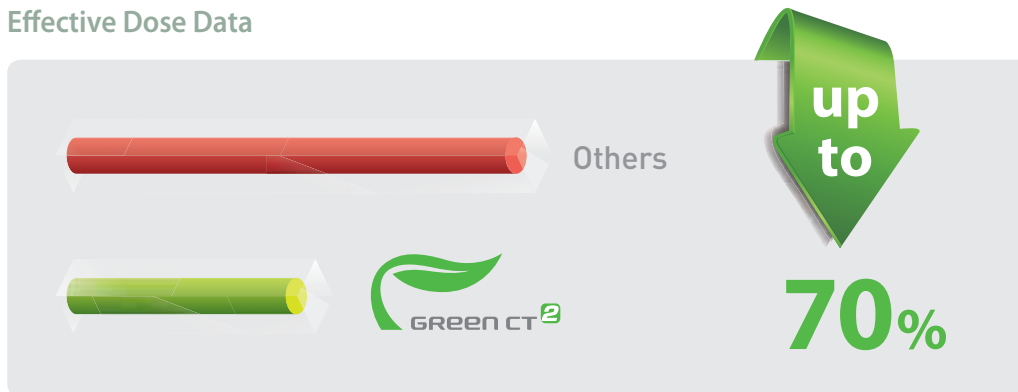

THE ART-V

Metal artifact hinders visualization and naturally reduces diagnostic confidence.

Clear images cause less stress and provide more confidence which lead to accurate diagnosis for implant planning.

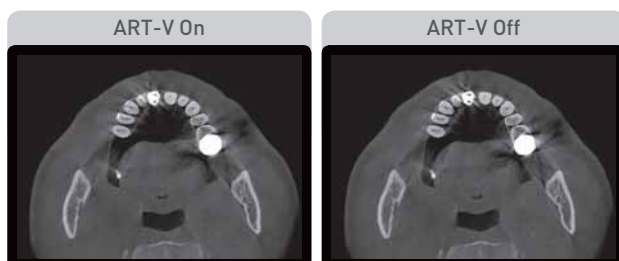

*ART-V is the new name of Vatech's MAR function. (Artifact Reduction Technology of Vatech)

3D SCANNING FOR MODEL

3D model scan enables users to store plasters as digital models.

DIGITIZED ONE-STOP CLINIC



CAD/CAM integration

- Sufficient level of detail for surgical guide design



Specially designed Jig

- Stable protection from partial model to full model

*3D scanning for Plaster Cast with FOV 8x9 (cm)

SPECIFICATIONS [Green CT 2 : PHT-65LHS]

Function	CT + Pano + Ceph + Model Scan	
Focal Spot Size	0.5 mm (IEC60336)	
CT FOV Size	16x9 cm : Multi [5x5 / 8x9 / 12x9 / 16x9 cm] 18x10 cm : Multi [5x5 / 8x9 / 13x10 / 18x10 cm]	
Voxel Size	5x5	0.08 mm / 0.12 mm
	8x9	0.12 mm / 0.2 mm
	12x9	0.2 mm / 0.3 mm
	13x10	0.2 mm / 0.3 mm
	16x9	0.2 mm / 0.3 mm
	18x10	0.2 mm / 0.3 mm
Scan Time	Pano	14.1 sec / 7.0 sec
	Ceph	3.9 sec / 1.9 sec
	CBCT	9.0 sec (12x9 - 18x10) / 4.9 sec (5x5 - 8x9)
Gray Scale	14 Bit	
Tube Voltage / Current	60 - 99 kVp / 4 - 16 mA	
Weight	Without CEPH unit	295.4 lbs - without the Base
		412.3 lbs - with the Base
	With CEPH unit	350.5 lbs - without the Base
		467.4 lbs - with the Base
Dimensions	Without CEPH unit	44.29" (L) x 58.61" (W) x 91.94" (H)
	With CEPH unit	73.78" (L) x 58.61" (W) x 91.94" (H)

*The specifications are subject to change without prior notice.

DIMENSIONS

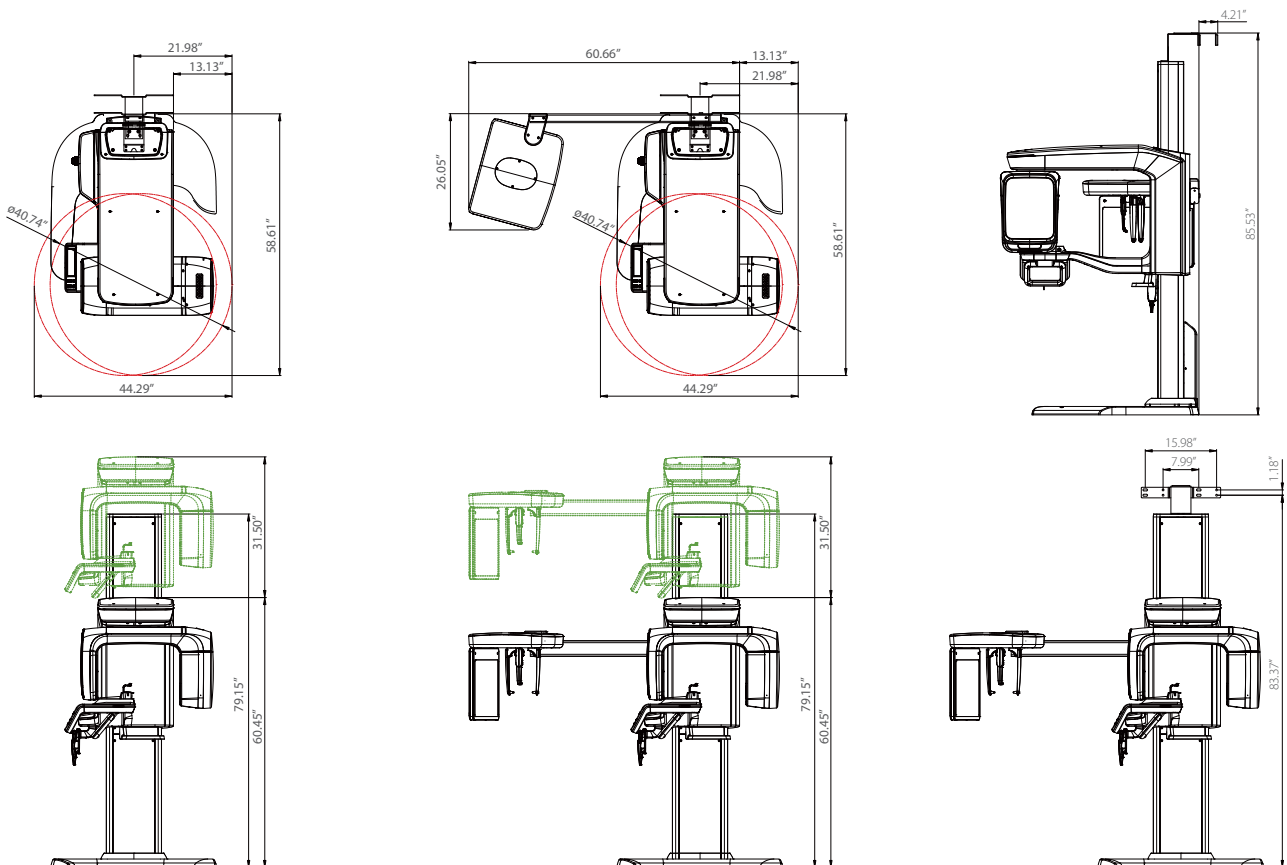

***An additional 3 inches (76.2 mm) of space is required behind the unit for wall mount bracket installation (mandatory unless there is a base mount installation).**

RAISING THE BAR FOR EXCELLENCE

i3D *Premium*

**LARGE 21X19 FOV FOR COMPLETE
DIAGNOSTIC IMAGING NEEDS**

**THE OPTIMAL SOLUTION FOR
AIRWAY AND ENT DIAGNOSIS**

**AUTOMATICALLY GENERATES UP TO
6 TYPES OF IMAGES IN 1 SCAN**



THE MOST SUITABLE FOV SIZE FOR A COMPLETE DIAGNOSIS

A 21x19 FOV is the optimal size for oral maxillofacial surgeons and orthodontists. Anatomically, it captures the regions from the roof of the orbits and nasion down to the hyoid bone.



- ✓ Oral and maxillofacial surgery
- ✓ Facial reconstructions
- ✓ Orthodontic treatment planning
- ✓ Complex orthognathic cases

The i3D Premium utilizes a proprietary 49.5 µm high resolution x-ray sensor, which makes it the finest pixel and highest resolution CBCT available on the market today.

[Multi FOV]

The i3D Premium offers a wide range of selectable Fields of View (FOV).

This selectable FOV helps limit patient radiation exposure, and allows users to capture only the region of interest. Clinicians can select between 21x19, 17x15, 17x11, 12x9, and 8x8 fields of view.

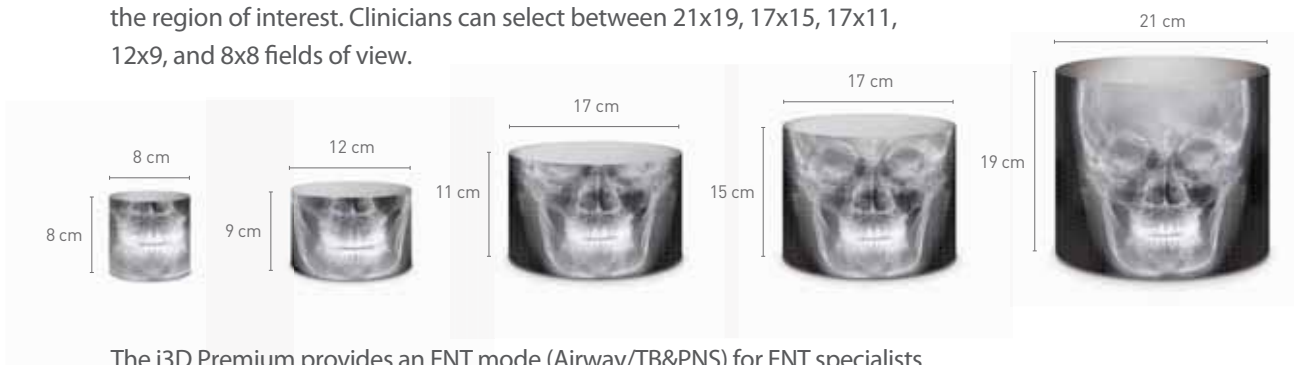

The i3D Premium provides an ENT mode (Airway/TB&PNS) for ENT specialists.

The fields of view are based on patients' most common cases such as cholesteatoma, chronic sinusitis, and sleep apnea.

[Airway] A Powerful Function for Airway Volume Analysis

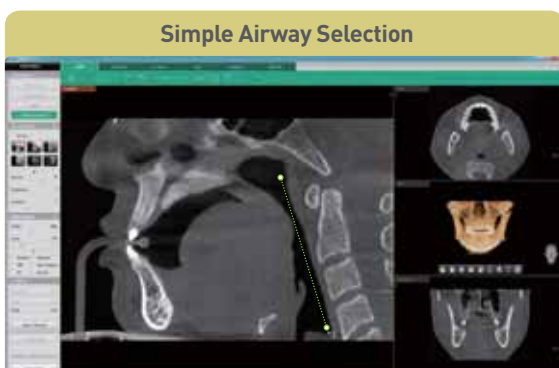

- 2-click airway region selection

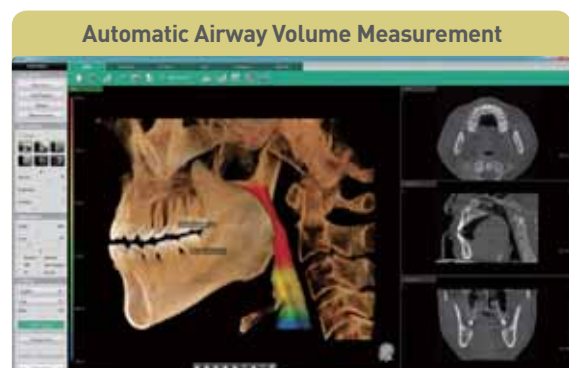

- Segmented airway volume and color coded thickness measurements
- Automatically calculates total volume and minimum area measurements

[TMJ] Simultaneous Analysis for both TMJ

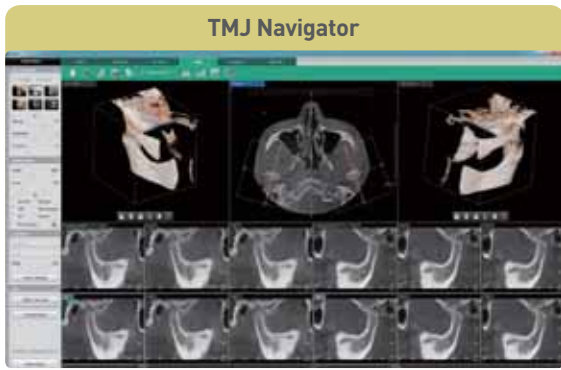

- Instant automatic cross-sectional images

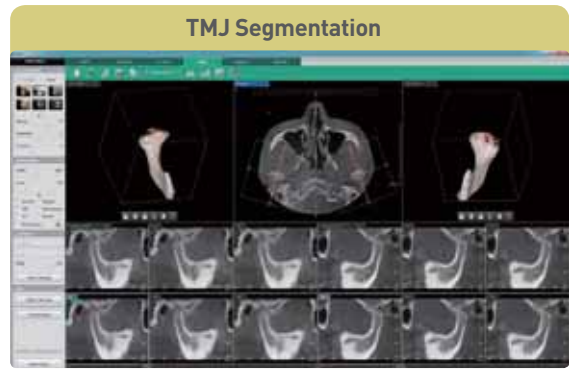

- Easily segment and separate the Condyle or Fossa
- Rotation for an accurate diagnosis

*Airway & TMJ analysis available on Ez3D-i V4.1

AUTOMATICALLY GENERATES UP TO 6 TYPES OF IMAGES IN 1 SCAN

One scan with the i3D Premium, can capture the raw data needed for a CBCT, Panorama, PA Ceph, Lateral Ceph, SMV Ceph, and Waters' View Ceph.

With this scan, the system is capable of capturing images for craniofacial, maxillofacial, and orthodontic treatment planning.

VALUE-ADDED AUTO IMAGE SELECTION



Select the image type needed for your treatment plan.

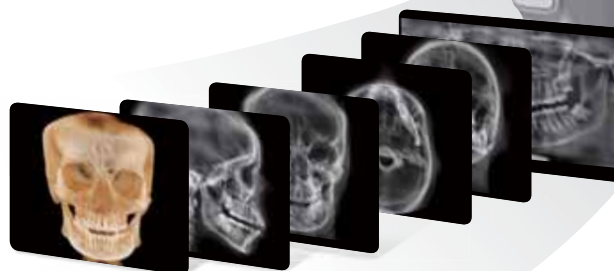

* Conventional Panorama mode is included.



DIMENSIONS

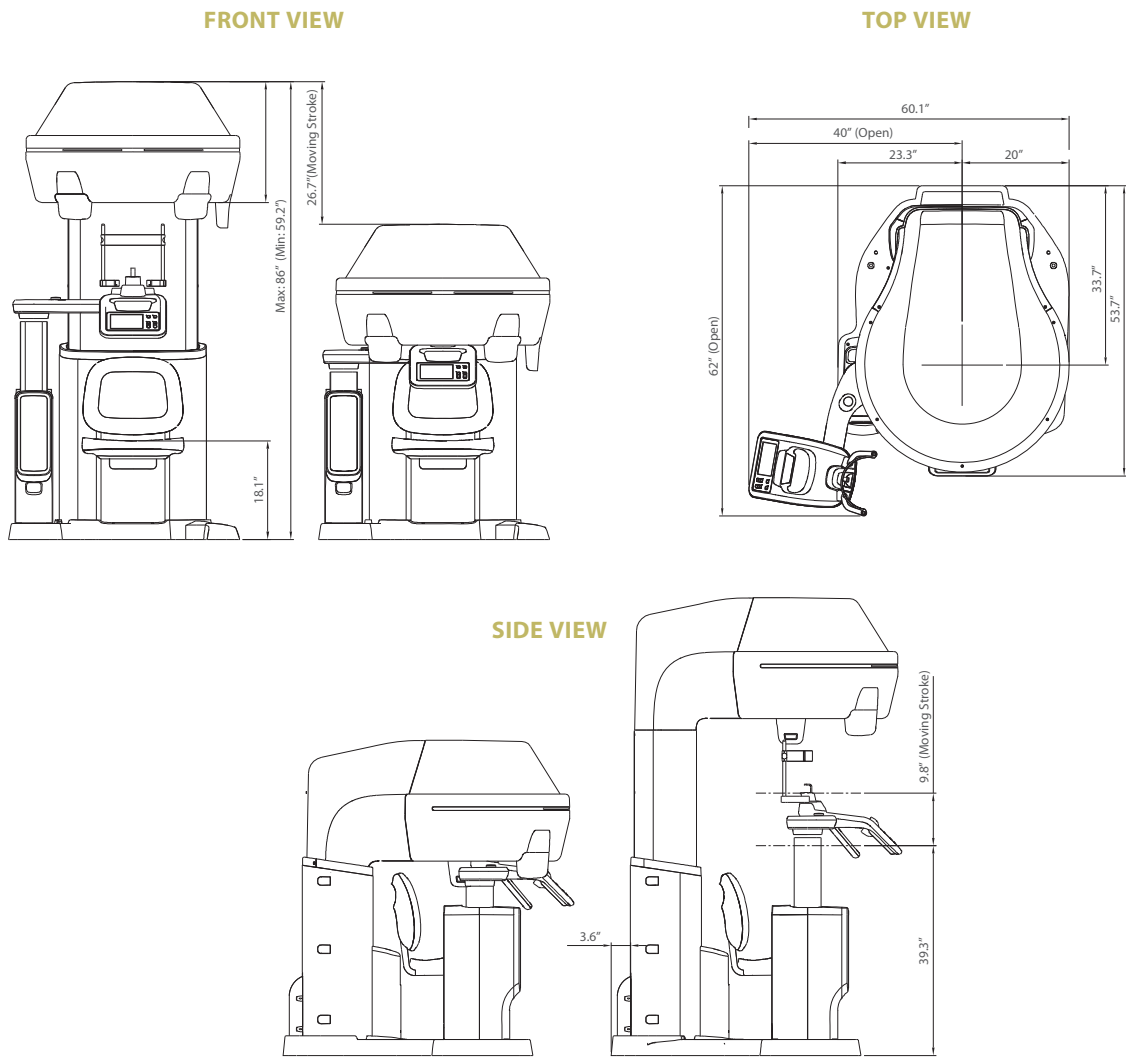

SPECIFICATIONS [i3D Premium : PCT-90LH]

Function	CT (Auto Pano/Auto Ceph) + Pano	
CT FOV Size	Dental	21x19 / 17x15 / 12x9 / 8x8 cm
	ENT	21x19 / 17x11[TB&PNS] / 17x11[Airway] cm
Scan Time	Pano	13.5 sec
	CT	Max. 18 sec
Voxel Size	0.2 / 0.3 / 0.4 mm	
Focal Spot Size	0.5 mm [IEC60336]	
Gray Scale	14 bit	
Tube Voltage	60 - 120 kV	
Current	4 - 10 mA	
Weight	321 kg (708 lbs)	
Dimensions	62"(L) x 60.1"(W) x 86"(H)	

• The specifications are subject to change without prior notice.

Ez3D-i

CUTTING-EDGE SOFTWARE FOR CUTTING-EDGE DIAGNOSTICS

Powered by a new 3D VR graphics engine, Ez3D-i is the ideal tool to quickly and easily obtain the correct perspectives needed for accurate, true-to-measurement diagnosis.

Quick and Easy **Dental 3D Imaging Software** for Every Dentist



PROVIDES QUICK AND ACCURATE DIAGNOSTIC TOOLS

- Various VR Coloring Modes and 2D Filters
- Intuitive Implant Simulation Tools
 - Collision Detection (Implant/Canal)
 - Bone Density Verification
 - Oblique Viewing Tools
- 3D Panoramic Navigation
- 2-Click Airway Analysis
- Multiple Sectional Curves and Segmentation Tools

CONSULTATION MODES INCLUDED

- Presentation Mode
- Over 200 Consultation Videos
- Easy to Capture Diagnostic Image
- 3D Panorama



Supports Various VR Coloring modes

- Teeth Mode
- Bone Mode
- Soft-Tissue Bone Mode
- MIP Mode
- Soft-Tissue Mode



Virtual Consultation Tool

- Over 200 Consultation Videos
- Creation of Personalized Consultation Materials



Implant Simulation

- 3 Click Implant Simulation
- Collision Detection
- Bone Density
- 3D Panorama
- Oblique View Mode

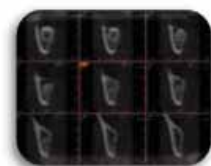

Provides Quick and Accurate Cross-Section

- 8 Multi-Section(Curve) Management
- One-Click Cross Section (3D PAN tab)
- Canal Drawing

VARIOUS VR COLORING MODES AND 2D FILTERS

- Switch quickly and easily between multiple VR views



2-CLICK AIRWAY ANALYSIS

- With two clicks, obtain the volume and minimum axial area of an airway for efficient airway diagnosis



FEATURING VATECH'S VIRTUAL CONSULTATION TOOL

- With over 200 unique animations, the virtual consultation tool gives you the tools to not only educate patients on treatment plans, but also to show how the plan is relevant to their specific case



3D PANORAMIC NAVIGATION

- Easily navigate and obtain a sectional view by utilizing our new and intuitive 3D panoramic navigation mode
- Simply click and drag our viewing window over the 3D panorama to obtain a sectional view of that region
- Angulation made easy



By clicking 3D Navigator and positioning to ROI, it's easy to verify 2D sectional images

IMPLANT SIMULATION

- Available in all viewing modes in Ez3D-i (MPR/Section/3DPan)
- Colorized bone density viewing modes available
- Adjustable automatic implant collision detection function between multiple implants and/or nerve canal



MPR tab



SECTION tab



3D PAN tab

MULTI-CURVE MANAGEMENT

- Draw sectional curves from either the MPR View or Sectional View
- Easily manage and up to 8 different sectional curves
- Intuitive click-and-draw sectional view manipulation

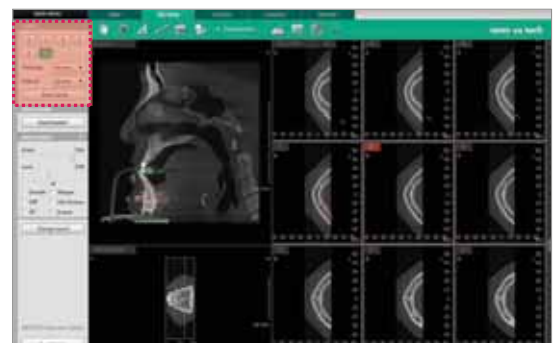

THE WORLD'S FIRST CLINICAL IMAGING & PATIENT CONSULTATION SOLUTION



Featuring... Vatech's Virtual Consultation Tool (VCT)

With over 200 unique animations, the virtual consultation tool gives you the tools to not only educate patients on treatment plans, but also to show how the plan is relevant to their specific case.



Get The Most Out Of Your Images

Using our revamped Sharpening and Max Sharpening tools, enhance the quality of your images even further than ever before.



Manage Your Images, The Easy Way

Organize and export your images quickly and efficiently and avoid complicated procedures and training using EzDent-i's intuitive Click-And-Drag based interface.





EzRay Air™ Wall

WEIGHT INNOVATION

WALL-MOUNTED INTRAORAL X-RAY



Round Shape Design

Stable Arm

One-Handed Grip

WEIGHT INNOVATION WITH CNT (CARBON NANO TECHNOLOGY)

The wall mounted EzRay Air Wall is a lightweight x-ray device designed for easy handling and stable positioning for optimal image quality on your intraoral x-rays.

The EzRay Air Wall's lightweight tube head provides users with a stable and easy to use x-ray source which maximizes image clarity and optimizes workflow.



SMART DIAL FOR ALL FUNCTIONS

The operating panel located on the tube head creates a much simpler and much faster workflow. Using the smart dial, practitioners will notice a decrease in preparation time and less of a need to remember complicated control buttons and configurations.

SECURE CLEAR IMAGES WITH A 0.4MM FOCAL SPOT

Compared to other intraoral x-rays on the market, the EzRay Air Wall provides optimal image quality and additional diagnostic value with a 0.4mm focal spot.



* Exposure Condition : 65kV, 3.0mA



SPECIFICATIONS [EzRay Air Wall : VEX-S300W]

Focal Spot	0.4 mm (IEC 60336)
Tube Voltage	65 kV
Tube Current	3.0 mA
Exposure Time Range	0.05 ~ 0.5 (0.01s increment)
Source to Skin Distance	Min. 7.9 inch
X-ray Field	Default: : 60 mm Round, 30x40 mm Rectangular / Optional: 20x30 mm Rectangular
Arm Length [Option]	62"/ 68"/ 80" *See note A
Accessories	Remote Exposure Switch (Hand Switch / Doorbell Switch)
Weight	56.9 lb (Arm Length 62")
	58.0 lb (Arm Length 68")
	61.1 lb (Arm Length 80")

* The specifications are subject to change without prior notice.

DIMENSIONS [Unit: inch]

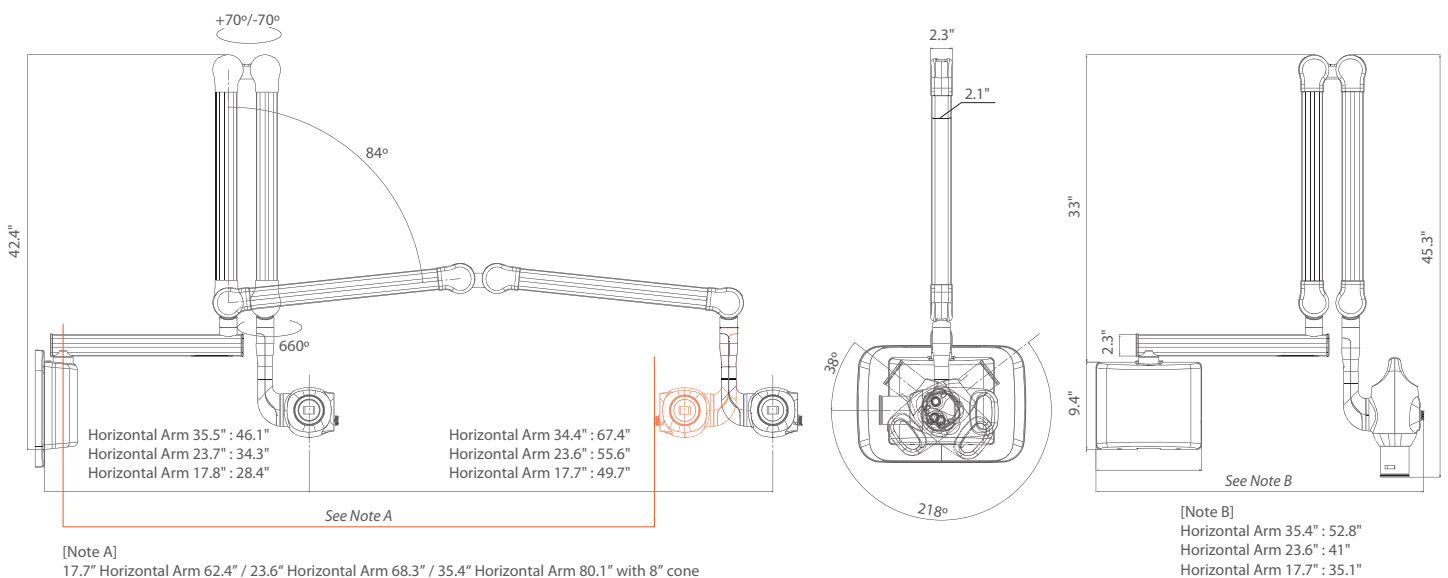

REDEFINING INTRAORAL SENSORS

HD Sensor



EXPERIENCE THE HIGHEST RESOLUTION



4.8 MM ULTRA-SLIM DESIGN



NEW CONTRAST FILTERS FOR YOUR PERFECT IMAGE



EXPERIENCE THE HIGHEST RESOLUTION

The HD Sensor is clinically usable at a wide range of exposure settings and is more consistent than all of the other sensors in the market. Practitioners benefit from reducing exposure-related retakes and find it less time consuming. Also, patients benefit from the reduction of radiation exposure. With our high sensitivity sensor, you can capture diagnosable images under any condition, even when using an old x-ray source.

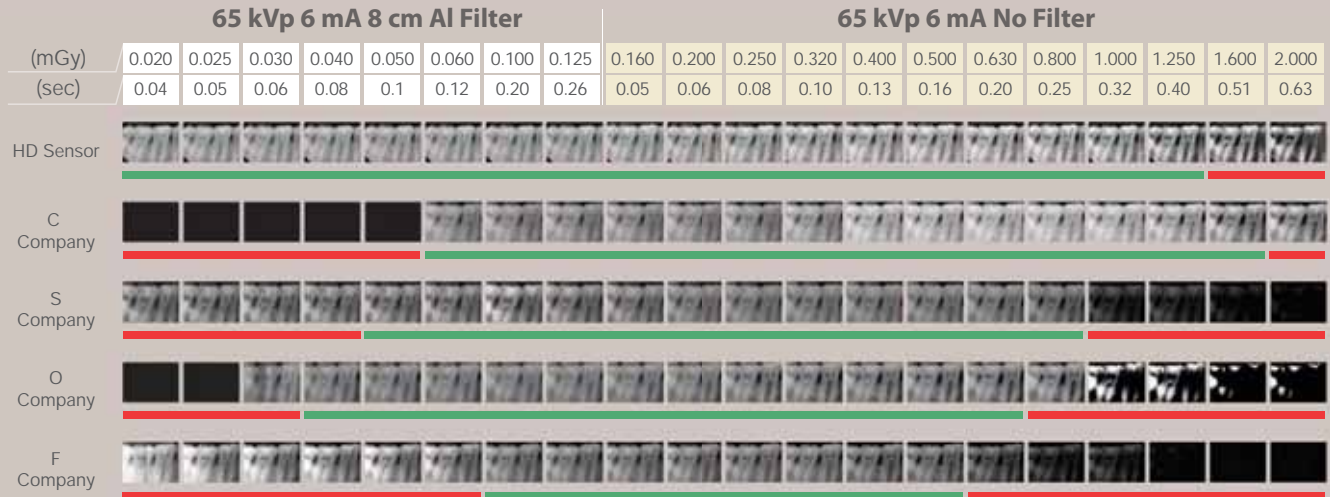

NEW CONTRAST FILTERS FOR YOUR PERFECT IMAGE

Switch quickly and easily among seven new contrast filters to find your perfect diagnostic image. Higher contrast filters can be utilized for periodontics, while lower contrast filters can be used for caries detection and restorative dentistry.

With the HD Sensor, you will always have these filters at your disposal.

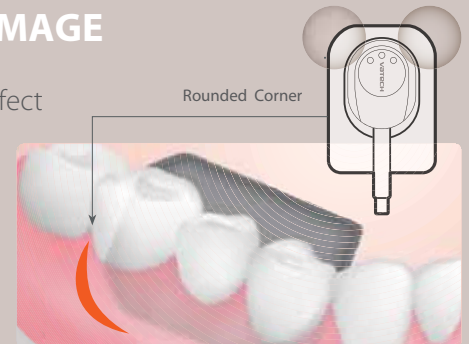

SPECIFICATIONS (HD Sensor : IOS-U10IF / IOS-U15IF / IOS-U20IF / IOS-U10VF / IOS-U15VF / IOS-U20VF)

Detector	CMOS	Pixel Size	14.8 μm
Theoretical Resolution	33.78 lp/mm	Dynamic Range	12 bit
Active Area (WxL)	Size 1.0 : 20x30 mm Size 1.5 : 24x33 mm Size 2.0 : 26x36 mm	Dimensions (WxLxT)	Size 1.0 : 25.4x36.8 mm (1.00"x1.45") Size 1.5 : 29.2x39.5 mm (1.14"x1.55") Size 2.0 : 31.3x42.9 mm (1.23"x1.69")
Thickness	4.8 mm (0.19")	Cable Length	2.7 m

* The specifications are subject to change without prior notice.

[Intended use]

An HD Sensor is intended to collect dental x-ray photons and convert them into electronic impulses that may be stored, viewed, and manipulated for diagnostic use by dentists.



vatech america

Vatech America, Inc. | Tel: (201) 210-5118 | sales@vatechamerica.com | 01 / 2019

www.vatechamerica.com